

FRANKE NYHET 2021

DECA 210-50

*Make
it
wonderful*

FRANKE

STÅL VASK DECA 210-50

127.0642.819 DECA 210-50 3 1/2" WWK TL TH WOF SIP BX

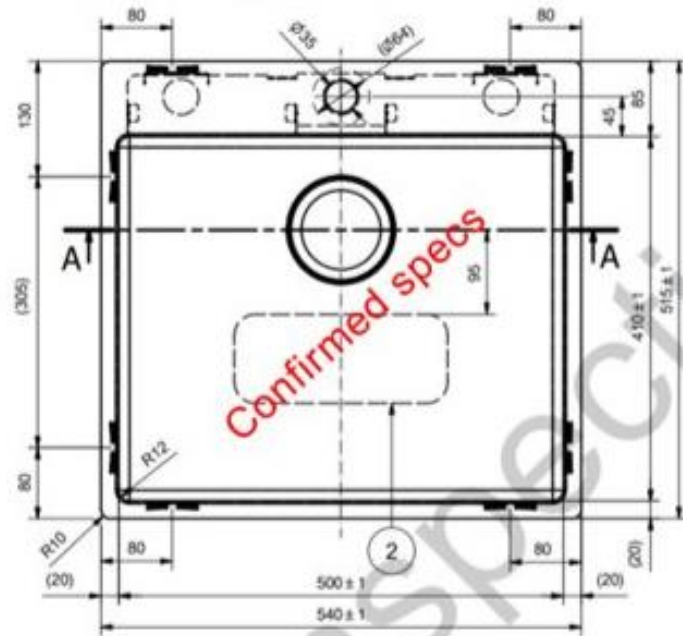

Produktegenskaper

- Vask med felt for armatur
- Stram, moderne design med rette kanter
- Avrundede hjørner for god mulighet til rengjøring.
- Børstet stål
- Fastfix installasjon («alle installasjonsmetoder)
- Passer fra 60 cm skap.

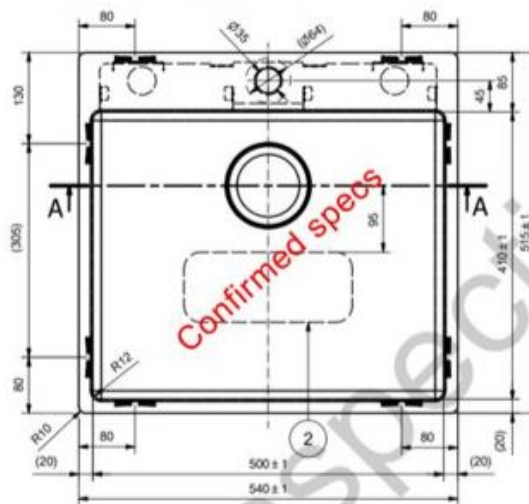

TEKNISKE DATA:

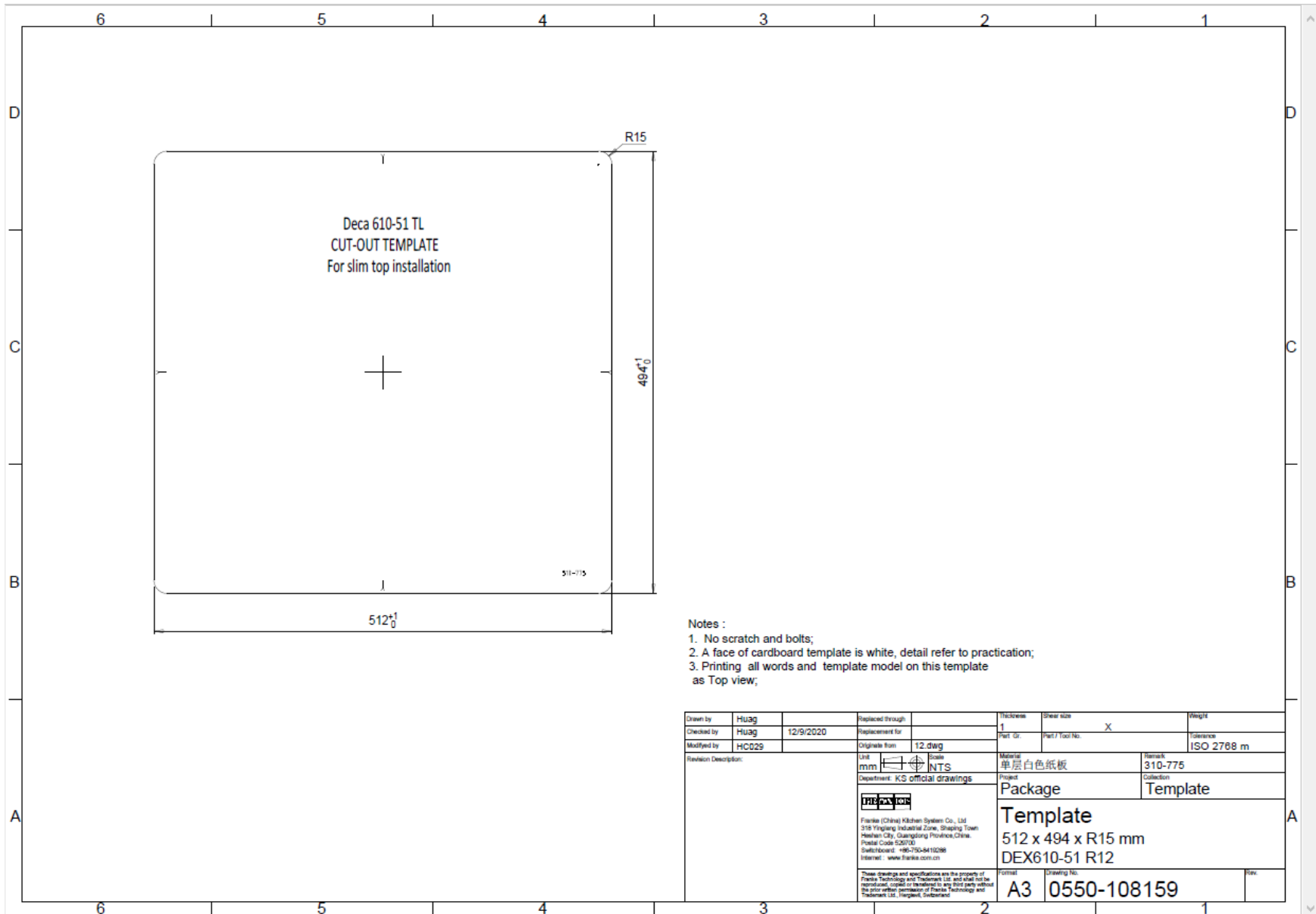

- Notes :
1. No scratch and bolts;
 2. A face of cardboard template is white, detail refer to practication;
 3. Printing all words and template model on this template as Top view;

Drawn by	HUag	Replaced through		Thickness	Sheet size	Weight
Checked by	HUag	12/9/2020	Replacement for	1	X	
Modified by	HCO2S		Original name	Part Gr.	Part / Tool No.	Tolerance
Revision Description:			12.dwg			ISO 2788 m
			Unit	Material		Remark
			mm	单层白色纸板		310-775
			Department: K/S official drawings	Project		Collection
				Package		Template
				Template		
				512 x 494 x R15 mm		
				DEX610-51 R12		
			Format	Sheet No.	Rev.	
			A3	0550-108159		